



**Techni**  
ENGINEERING SOLUTIONS

**RENAULT TRAFIC / VAUXHALL GM / VIVARO  
FIAT TALENTO / NISSAN NV300**

**1.6 dCi / CDTi Euro 5B+ /Euro 6  
90, 115, 120, 140**

---

**CODE / CODICE: 0500.7612**

**COMPRESSOR / COMPRESSEUR / KOMPRES-  
SOR / COMPRESSORE / COMPRESOR :**

**VALEO : TM13 / 15**

**QUE : QP13 / 15**

---

**FITTING INSTRUCTIONS**

**EINBAUANLEITUNGEN**

**INSTRUCTIONS POUR LE MONTAGE**

**ISTRUZIONI DI MONTAGGIO**

**INSTRUCCIONES DE MONTAJE**

---



**Contents**

<b>ENGLISH</b> .....	4
Parts View.....	4
Parts List .....	5
Compressor Configurations .....	6
Standard Fastener Torque Values .....	6
Kit Details .....	7
Vehicle Details .....	7
Forward .....	7
Pre Installation.....	8
Installation .....	9
Bracket Installation.....	10
Compressor Installation .....	10
Idle Pulley / Tensioner Installation .....	11
Vacuum Solenoid Installation .....	13
Refrigerant Hose Routing .....	13
Electrical Interface .....	14
Post Installation.....	14

PARTS VIEW / VUE ÉCLATÉE / TEILEANSICHT / VISTA PARTA / IMÁGENES DE LAS PIEZAS

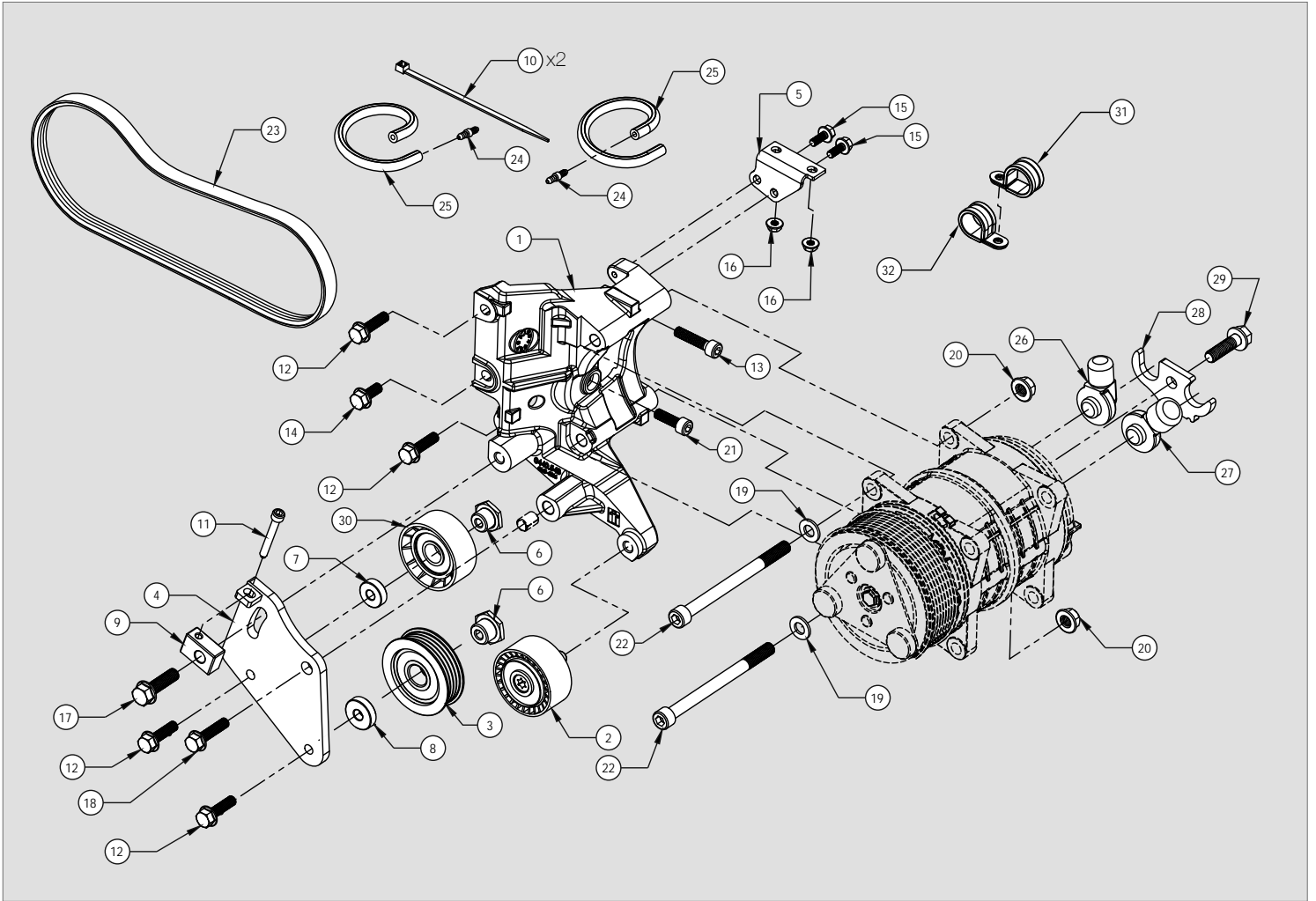

## PARTS LIST / NOMENCLATURE / TEILELISTE / ELENCO DELLE PARTI / LISTA DE PIEZAS

ITEM	CODE / CODICE / KODE / CODIGO	DESCRIPTION / DESCRIZIONE / BESCHREIBUNG / DESCRIPCION	QTY.	COMMENTS
1	0441.5481	Compressor mount bracket assembly 1.6 R9M	1	-
2	1700.5231	Idler 6PK Ø 60 inc M10 cap bolt	1	-
3	1700.5321	4PK Idle Pulley Ø60 (Included Cap)	1	-
4	3020.6301	Adjuster plate assembly 1.6 R9M	1	-
5	3020.6311	Solenoid Mount 1.6 R9M	1	-
6	2803.5961	Pulley nut 24mm A/F	2	-
7	2803.6051	Spacer Ø23 L8.5mm Ø8.5	1	-
8	2803.6061	Spacer Ø25 L6.7 Ø8.5	1	-
9	1703.5021	Adjuster block M6 (Typ3)	1	-
10	2763.0051	Cable Tie 4.8 x 370 - Black	2	-
11	2702.5021	Socket Cap Machine Screw M6 x 45 :1.0 - 12.9	1	-
12	2704.0091	Hex flange bolt Durlok - M8 x 30 : 1.25 - 12.9	4	-
13	2704.5541	Hex socket head cap screw M8 x 35 : 1.25 - 12.9	1	-
14	2704.0511	Hex flange bolt - M8 x 20 : 1.25 - 10.9	1	-
15	2702.0131	Hex flange bolt Durlok - M6 x 16 : 1.00 - 12.9	2	-
16	2732.0041	Hexagon flange nut Durlok - M6 : 1.00	2	-
17	2705.0241	Hex flange bolt Durlok - M10 x 35 : 1.50 - 12.9	1	-
18	2704.0481	Hex flange bolt Durlok - M8 x 35 : 1.25 - 12.9	1	-
19	2809.0011	Washer M10 Flat DIN 125 - A 10.5	2	-
20	2735.0071	Durlok Hexagon Flange Nut - M10 : 1.50	2	-
21	2704.5371	Hex socket head cap screw M8 x 25 : 1.25 - 12.9	1	-
22	2705.0301	Hex socket head cap screw M10 x 130 : 1.50 - 12.9	2	-
23	0820.7281	Belt - Poly Groove 4PK 1170	1	-
24	1494.0031	Hose Connector (Ø4 hose)	2	-
25	1440.0131	Vacuum hose 100mm	2	-
26	0426.5042	Compressor Fitting - Discharge 3/4 -16- Type B	1	-
27	0426.5032	Compressor Fitting - Suction 7/8 -14 Type B	1	-
28	3020.6201	Manifold pipe clamp `D`	1	-
29	2705.5301	Hex Flange Bolt -M10 x 35 : 1.50 -8.8	1	-
30	1700.0341	Idle Pulley 60.2 X 25.5	1	-
31	2771.1031	P Clip 19mm	1	-
32	2771.1071	P Clip 21mm	1	-

**COMPATIBLE COMPRESSORS / COMPRESSEURS RECOMMANDÉS / EMPFOHLENE KOMPRESSOREN  
RACCOMANDATO COMPRESSORI / RECOMENDADAS COMPRESORES**

SELTEC	TM13-HD	TM15-HD	TM16-HD
Comp No	0381.0202	0381.0002	-
Valeo No.	N204832G	N204825L	-
Mounting	EAR	EAR	-
Rotor	8PV	8PV	-
Armature	3E	3E	-
GL	46.55	46.55	-
Diameter	123	123	-
Voltage	12	12	-
Orientation	V	V	-
Fitting	3/4 x 7/8	3/4 x 7/8	-
Manifold	Bolt	Bolt	-

DELPHI	-	-	-
Comp No.	-	-	-
Delphi No.	-	-	-
Mounting	-	-	-
Rotor	-	-	-
Armature	-	-	-
GL	-	-	-
Diameter	-	-	-
Voltage	-	-	-
Orientation	-	-	-
Fitting	-	-	-

QUE	QP13-HD	QP15-HD	QP16-HD
Comp No	0391.0202	0391.0002	-
Que No.	QP13-1302	QP15-1171	-
Mounting	EAR	EAR	-
Rotor	8PV	8PV	-
Armature	3E	3E	-
GL	46.55	46.55	-
Diameter	123	123	-
Voltage	12	12	-
Orientation	V	V	-
Fitting	3/4 x 7/8	3/4 x 7/8	-
Manifold	Bolt	Bolt	-

SANDEN	-	-	-
Comp No	-	-	-
Sanden No.	-	-	-
Mounting	-	-	-
Rotor	-	-	-
Armature	-	-	-
GL	-	-	-
Diameter	-	-	-
Voltage	-	-	-
Orientation	-	-	-
Fitting	-	-	-

**STANDARD FASTENER TORQUE VALUES**

In the absence of specific torque values detailed in this fitting instruction manual, the following chart can be used as a guide to the maximum safe torque for specific size and grade of fastener.

**COUPLES DE SERRAGE DES FIXATIONS STANDARDS**

Si des chiffres de serrage au couple particuliers ne sont pas indiqués dans cette notice de montage, se référer au tableau suivant qui servira de guide pour le couple de sécurité maximum correspondant à une taille et un grade spécifiques de fixation.

**ANZIEHMOMENTE FÜR STANDARDBEFESTIGUNGSMITTEL**





Falls in dieser Einbauanleitung keine speziellen Anziehmomente angegeben sind, kann die folgende Tabelle als Richtlinie für das maximale sichere Anziehmoment für eine spezifische Größe oder Qualität von Befestigungsmitteln dienen.

**VALORI STANDARD DI SERRAGGIO PER DISPOSITIVI DI FISSAGGIO**

In assenza di valori specifici di coppia nel presente manuale di istruzioni, si può utilizzare la seguente tabella come guida per conoscere la coppia massima sicura in base a dimensioni e grado del dispositivo di fissaggio.

**VALORES ESTÁNDAR DE LOS PARES DE APRIETE Y FIJACIÓN**

En ausencia de valores para los pares de apriete específicos detallados en este manual de instrucciones de montaje, se puede utilizar la siguiente tabla como guía para consultar el máximo par de torsión seguro para un tamaño concreto y su grado de fijación.

STRENGTH								
	Max Torque		Max Torque		Max Torque		Max Torque	
Dia / Pitch	lb.ft	Nm	lb.ft	Nm	lb.ft	Nm	lb.ft	Nm
M5 x 0.80	2	3	4.5	6	6.5	9	7.5	10
M6 x 1.00	4	5.5	7.5	10	11	15	13	18
M8 x 1.25	10	13	18	25	26	35	33	45
M10 x 1.25	20	27	39	53	57	78	66	90
M10 x 1.50	18	25	37	50	55	73	63	86
M12 x 1.75	33	45	63	85	97	130	111	150
M14 x 2.00	55	75	103	140	151	205	177	240
M16 x 2.00	85	115	159	215	232	315	273	370

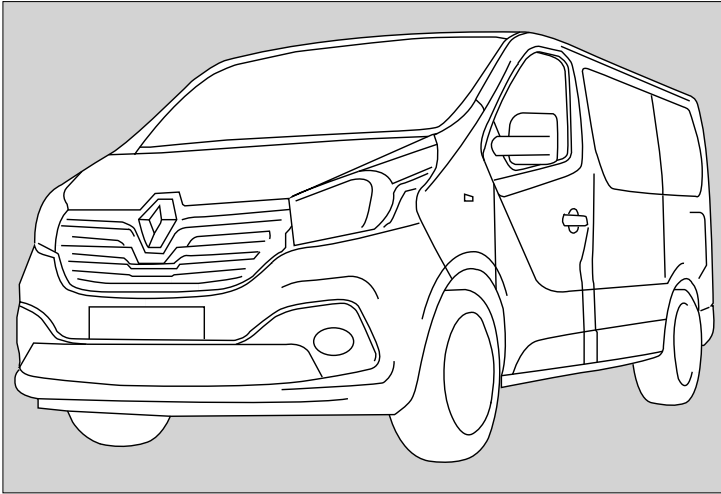

## VEHICLE DETAILS

Manufacturer	Renault / Vauxhall GM / Fiat / Nissan
Model	Trafic / Vivaro / Talento / NV300
Type	1.6 dCi / CDTi 90, 115, 120, 140
Engine Details	Euro 5B+/Euro 6 R9M408 / R9M450
Year	10.14>
Chassis Nos.	N/A
LHD	YES
RHD	YES
PAS	YES
A/C	YES/NO
Voltage	12v

## KIT DETAILS

Kit Part No.	0500.7612
Description	Standard Kit
Compressor RPM	3600 @ Max Engine Power Output
Fitting Time	- AC 40 Minutes / +AC - 60 Minutes
Suction Fitting	45°
Discharge Fitting	90°
Compressor Drive Belt	4PK 1170
Belt Part No.	0820.7281
Note	With option power take off - PFMOT / V66

## FOREWORD

The purpose of this manual is to facilitate the installation of a direct drive compressor. The information given is merely instructive, should any complications arise contact the Technical department. The manufacturer's warranty does not cover any problems caused by defective installation or alterations made unless authorised. The manufacturer shall not be responsible for any injury, damage or loss caused directly or indirectly as a result of using this manual or the information contained within it.

### 1 SAFETY MEASURES:

**Before fitting the Compressor adapter drive kit, ensure the following for damage:**

- a Inner and outer trim and body work
- b Engine idle pace
- c Check all the vehicle functions

**Check list:**

- a Ensure that the right kit has been selected
- b Before installing, check that all the correct pieces are present; also ensure that there are no missing or broken pieces
- c When fitting, make sure the vehicle is properly protected against damage.

### Installation apparatus

- a Calibrated torque wrench
- b Hand service tools
- c Protective covers and shields

### 2 PRECAUTIONS

- a Detach the battery negative lead.
- b Torque all bolts where stated using a calibrated torque wrench.
- c Take extreme care with moving parts.
- d Remove the vehicle's ignition key and keep it with you.
- e Wear safeguards and make sure that liquid refrigerant never touches your skin

**Caution:** Measures must be followed accurately to steer clear of the possibility of damage to individuals

**Warning:** This calls awareness to actions which must be pursued to avoid damage to the components.

**NB:** This calls awareness to make the job easier or gives useful information.

**PRE-INSTALLATION**

**N.B** Prior to commencing work, please examine the instructions with care. The alphabetical symbols on the diagram relate to written instructions, numerical symbols relate to the parts listing.

1. Removal of parts:  
Under panel **A** - Fig 1

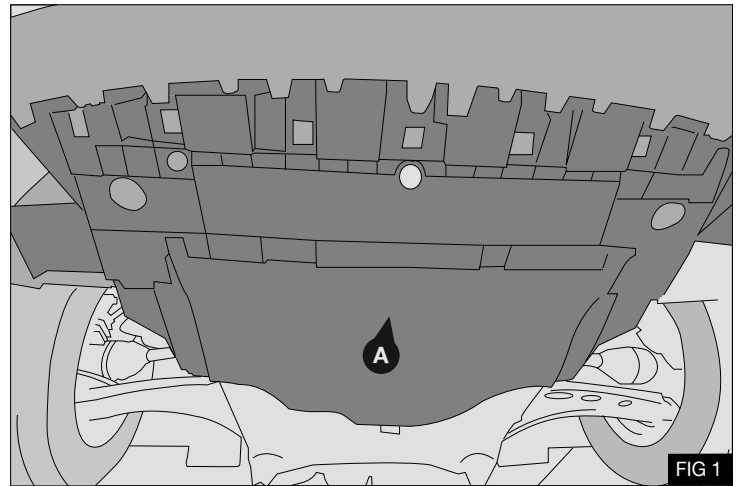

2. Side panel **B** - Fig 2

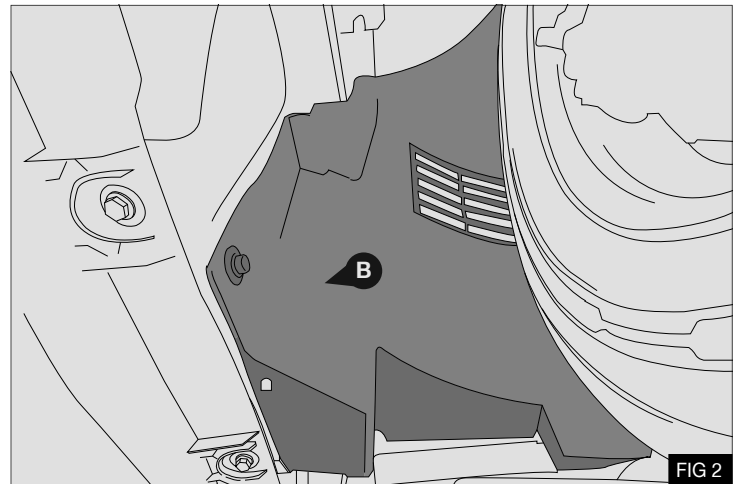

3. Washer bottle neck **C** - Fig 3

**With AC only**

4. Air intake pipe **D** (protect opening on the engine side) - Fig 3

**With AC only**

5. Separate the air intake box **E** 3x screws and 1x spring clip, disconnect wiring harness and remove the upper section - Fig 3

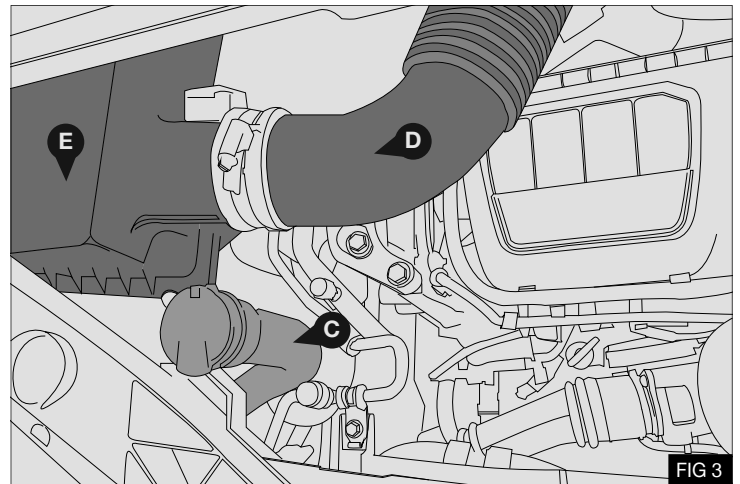

**With AC only**

6. Remove the 2x screws securing the air box lower section  
**F** Disconnect drain tube (not shown) by turning 90 degrees  
Clockwise - Fig 4

**With AC only**

7. Remove lower air box and intake pipe **G** - Fig 4

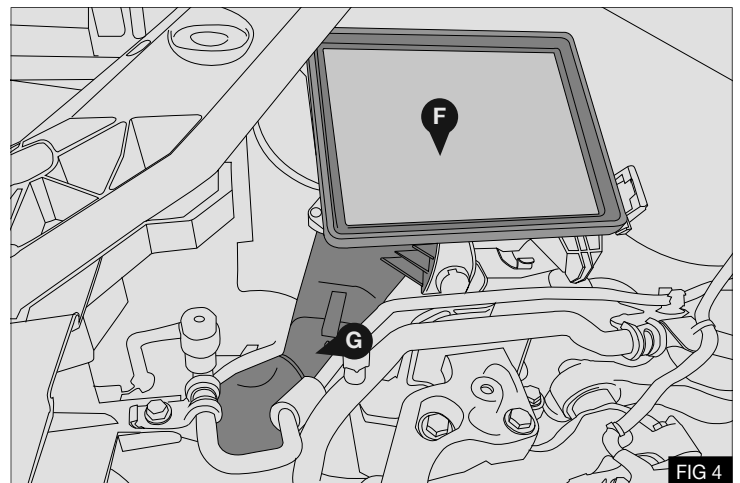



8. Disconnect air pipe **H** from housing - Fig 5
9. Remove and discard bracket **I** mounting vacuum solenoid **J** retain cap head screws **K** (disconnect pipes and wiring harness) - Fig 5

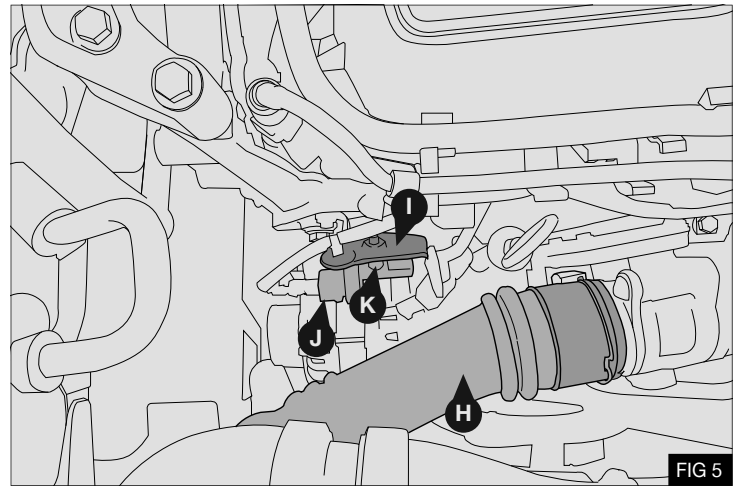

10. Remove wiring harness connection **L** from dipstick tube, reposition harness bracket **M** as shown - Fig 6
11. Secure harness connection **L** to dipstick tube with cable tie **10** as shown - Fig 8

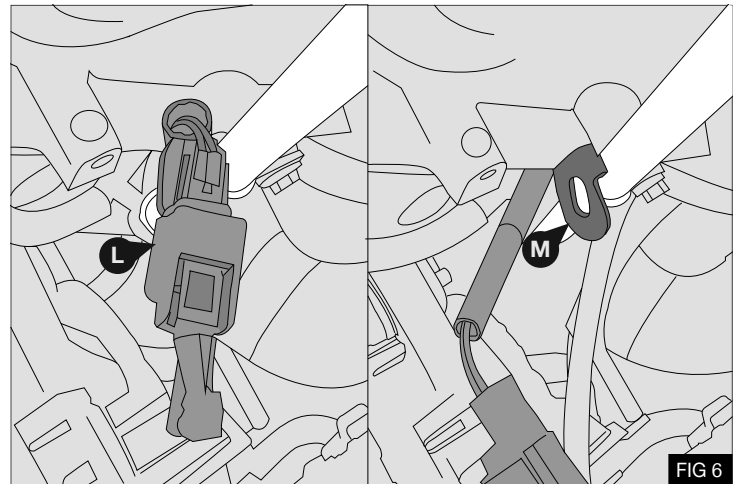

#### Without AC only

12. Remove and discard original idle pulley cover **N** - Fig 7

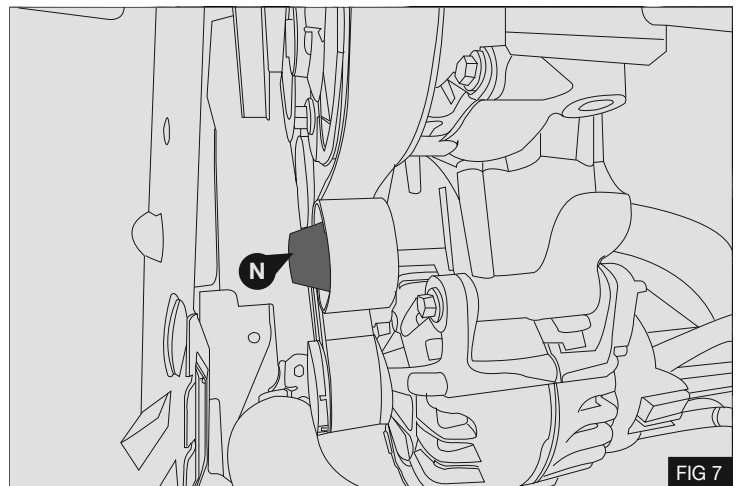

#### INSTALLATION

1. Extend existing vacuum hoses using connectors **24** and hose **25** - Fig 8

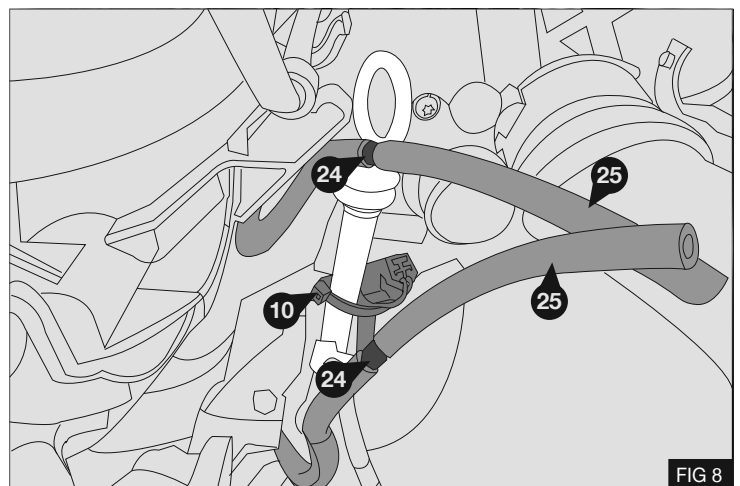

**BRACKET INSTALLATION**

1. Fit bracket (1) using 2 x M8 x 30 flange bolts (12) 1 x M8 x 20 flange bolt (14) 1 x M8 x 25 Cap head screw (21) and 1 x M8 x 35 Cap head screw (13) - Figs 9 & 10
2. Torque bolts (12), (14), (21) and (13) to 29Nm / 21.4Lbft

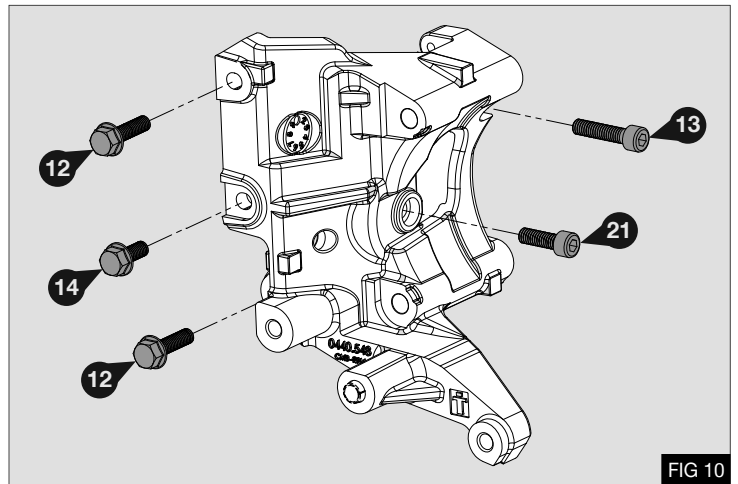
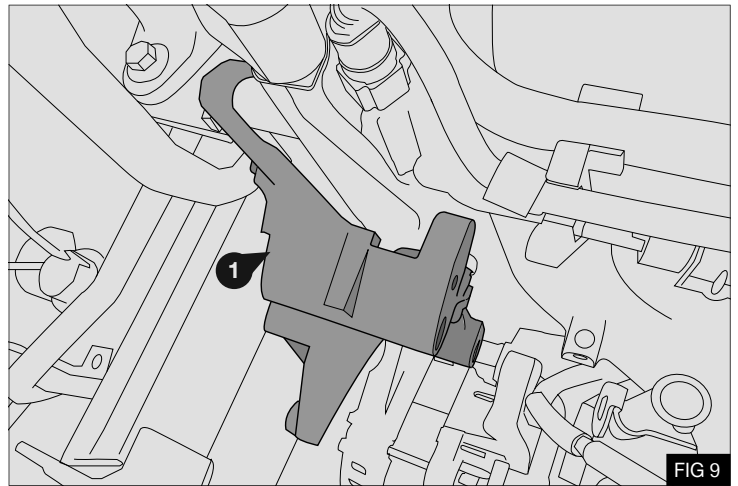

**COMPRESSOR INSTALLATION**

1. Modify compressor by removing mounting ears as indicated - Fig 11

**Caution:** This operation must be followed exactly to prevent interference with engine components.

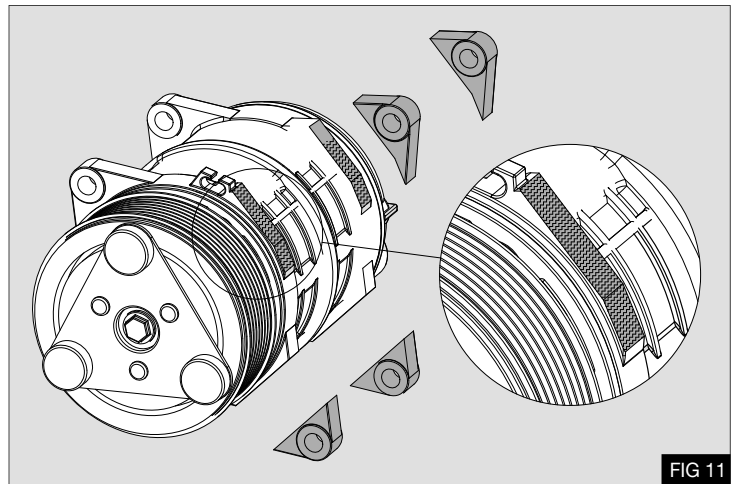

2. Fit compressor manifold components (26), (27), (28) and secure using M10 x 35 flange bolt (29) - Fig 12

**N.B** Ensure the clamp is installed in the correct orientation with the notch below the suction port (see detail A) - Fig 12

3. Torque bolt (29) to 45Nm / 33Lbft

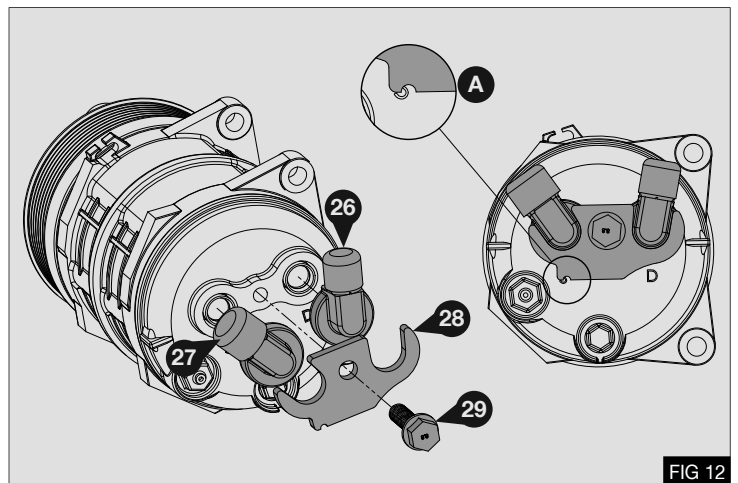

4. Fit prepared compressor (N) to bracket using 2 x M10 x 130 Cap head screws (22) with washers (19) and M10 nuts (20) - Fig 13
5. Torque bolts (22) to 50Nm / 37Lbft

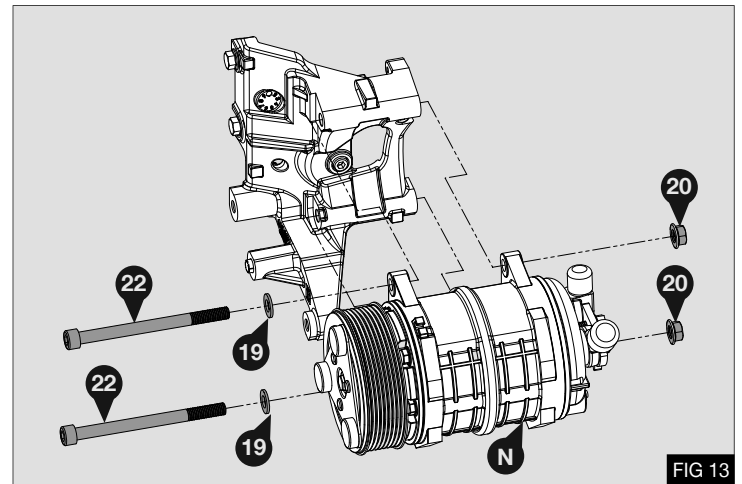

FIG 13

### IDLE PULLEY / TENSIONER INSTALLATION

1. Install back idler pulley (2) with its bolt to point shown - Fig 14
2. Torque bolt (2) to 45Nm / 33Lbft

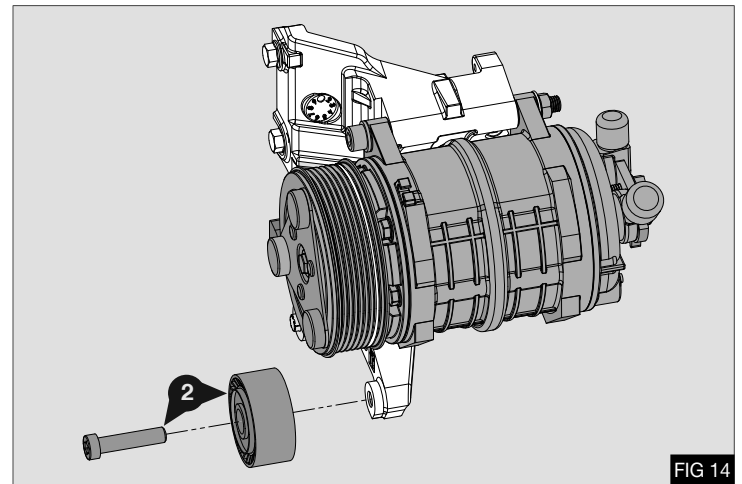

FIG 14

3. Fit back idler pulley (30) to tensioner plate (4) using M8 x 30 flange bolt (12) spacer (7) and pulley nut (6) - Fig 15
4. Fit grooved idle pulley (3) to tensioner plate (4) using M8 x 30 flange bolt (12) spacer (8) and pulley nut (6) Torque bolt and install pulley cap - Fig 15
5. Torque bolts (12) to 29Nm / 21.4Lbft

**Caution:** Ensure spacers (7) and (8) are installed in the correct locations.

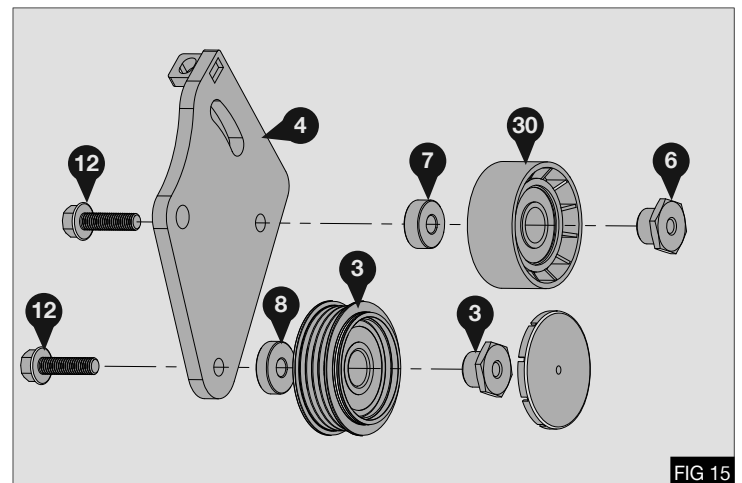

FIG 15

6. Assemble adjuster block (9) onto adjuster plate (4) using M6 x 45 cap head bolt (11) - Fig 16

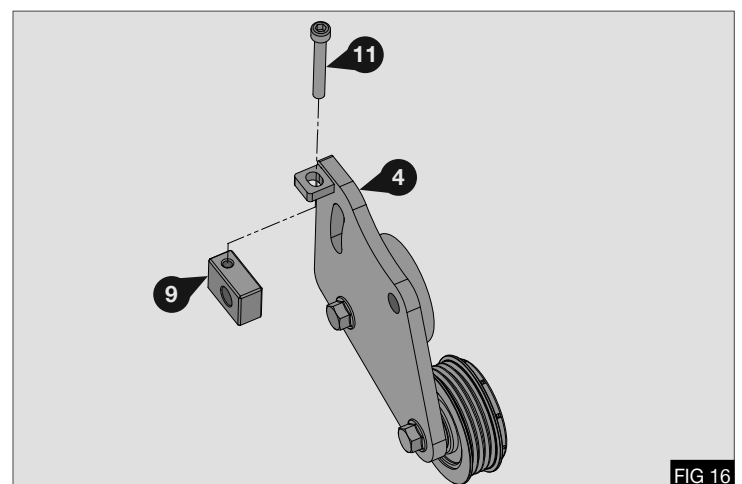
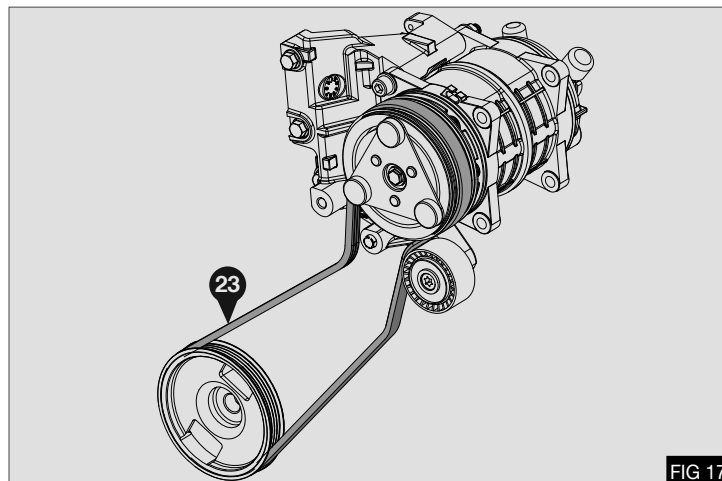

FIG 16

7. Position drive belt (23) as shown - Fig 17



8. Fit tensioner assembly (4) onto bracket using M10 x 35 flange bolt (17) through the adjuster block (9) and into the bracket (1), install M8 x 35 flange bolt (18) through adjuster plate (4) into bracket (1) - Fig 18

**Caution:** During this operation the drive belt needs to be positioned correctly onto the pulleys.

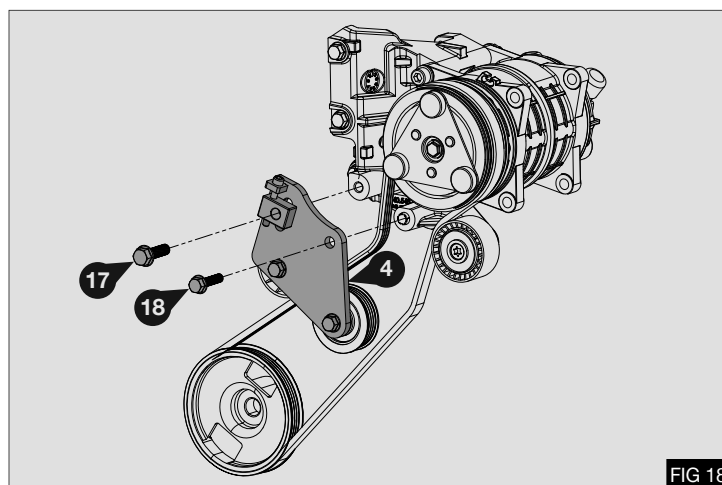

9. Position the drive belt (23) onto the compressor as shown - Fig 19

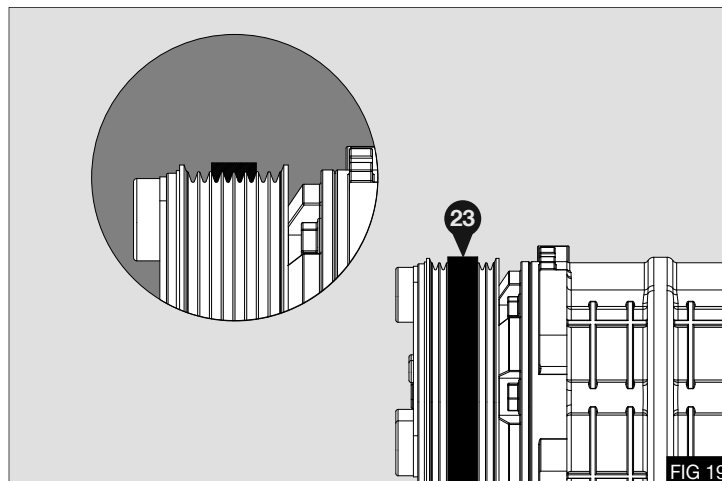

10. Check belt is seated correctly in all pulleys, tension belt using adjuster draw bolt (11) once correct tension is achieved (see table) check belt is correctly positioned and tighten bolts (17), (18) - Fig 20

11. Torque bolt (18) to 29Nm / 21.4Lbft

12. Torque bolt (17) to 50Nm / 37Lbft

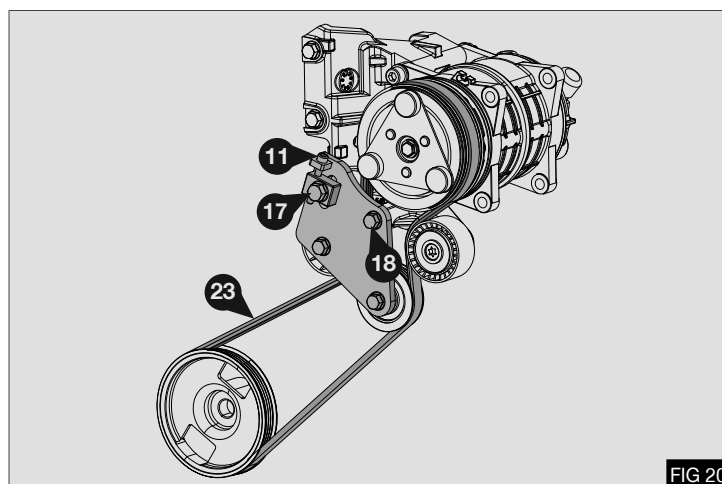

**BELT TENSION TABLE**

Belt	Belt Age	Belt Tension Using Belt Tension Gauge
4PK	New Belt	48 - 56 kg
4PK	Used Belt	36 - 40 kg

**VACUUM SOLENOID INSTALLATION**

1. Fit vacuum solenoid bracket (5) to mount bracket (1) using M6 x 16 flange bolts (15). Secure vacuum solenoid (J) to bracket (5) using original cap head screws (K) with nuts (16). Re-connect wiring harness to solenoid - Fig 21
2. Torque bolts (15) and (K) to 10 Nm / 7.5Lbft

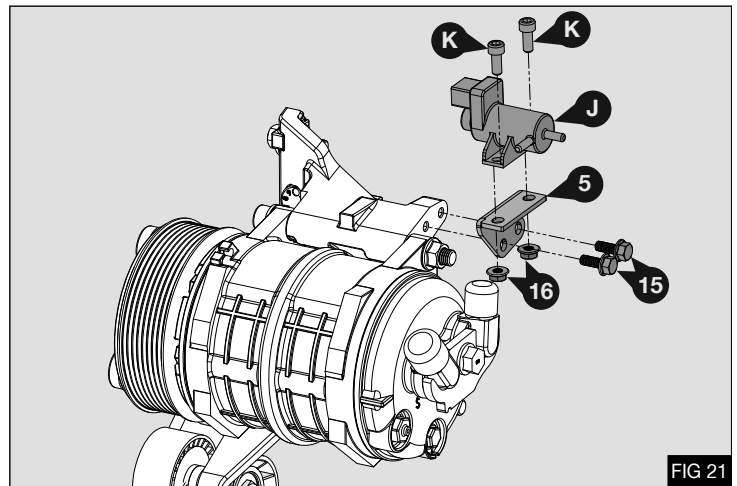

FIG 21

3. Connect previously installed vacuum hose extensions (25) to vacuum solenoid (J) - Fig 22

**NB** Ensure the hoses are connected to the correct positions on the solenoid

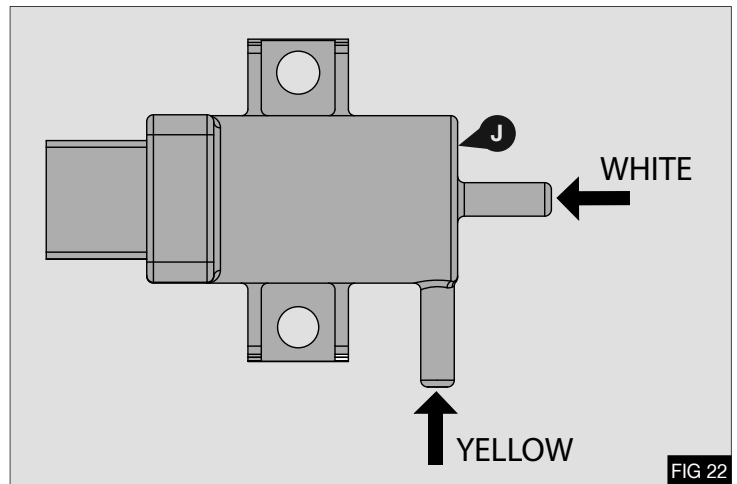

FIG 22

**REFRIGERANT HOSE ROUTING**

1. Fit compressor hoses as shown - Fig 23 & 24
  - a Discharge fitting - 90 degrees
  - b Suction fitting - 45 degrees
2. Re connect air pipe (H) once the hoses are correctly installed - Fig 23

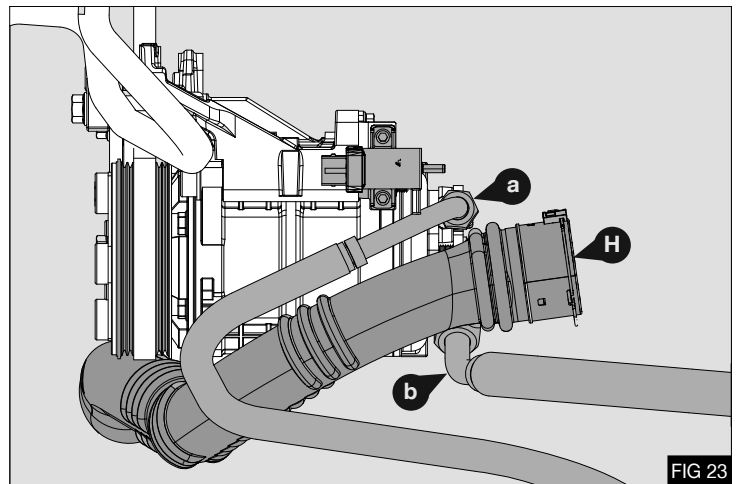

FIG 23

3. Secure the hoses (a) & (b) to the air intake using the original screw (P) and p-clips (31) & (32) along with cable tie (10) - Fig 24

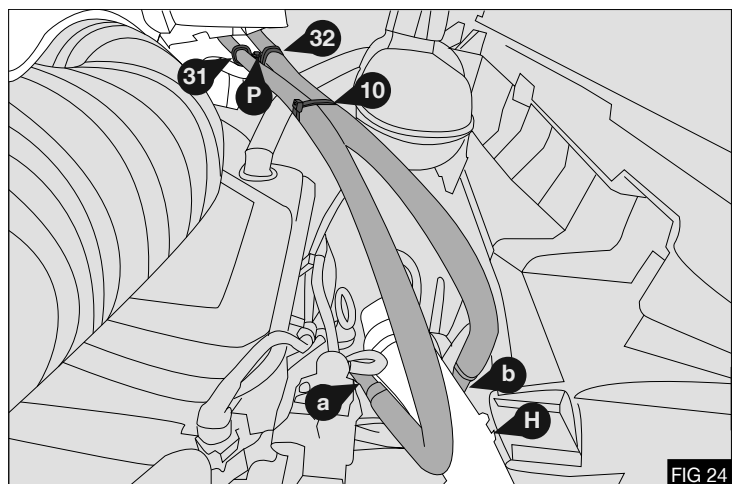

FIG 24

**ELECTRICAL INTERFACE**



1. Vehicles fitted with Stop / Start technology must have the fast idle activated when combined with this compressor mount kit.
2. Full details of how to complete this operation are contained within the Renault / Vauxhall / GM conversion guidelines for this vehicle in the following locations -
3. Renault - 4.9 "CABADP" option / fast idle "RALENT" option
4. Vauxhall / GM - 4.9 wiring loom for conversions option "KPD" / fast idle option "UF3"
5. The fast idle is activated by connecting pin 2 of the 6 way connector (P) to earth – Fig 25
6. Manufacturers recommend that this connection is activated whenever the refrigeration / additional AC system is active
7. The 6 way connector (P) (black plug) is located in the left hand area of the dashboard behind the passenger compartment fuse and relay box. It is secured on the dashboard wiring using a tear-off link. Extra length is provided for the connection - Fig 26
8. The manufacturers provide a +12V battery power supply for use with auxiliary component wiring via a 2-way connector (Q). This connector is located beneath the drivers seat - Fig 27

- Pin 1: +12V direct battery power supply for maximum consumption of 40A (wire section 7mm<sup>2</sup>). Protected by a 50A fuse.
- Pin 2: Ground (wire cross-section 7mm<sup>2</sup> large enough to adapt to the battery +12V current).

**NB** The maximum permanent current of this power supply must not exceed 40A. This line is protected by the 50A fuse fitted in the electrical distribution unit (BDU)

**POST INSTALLATION**

1. Before starting the engine check all the installed parts and ensure that the belt is installed correctly. Run the unit for at least ten minutes, then check the whole mounting assembly and previously removed parts. Attach the supplied warning label on to a suitable location.
2. Run engine with refrigerant compressor engaged for 10 minutes. Allow drive belts to cool and re-tension as necessary (See table).

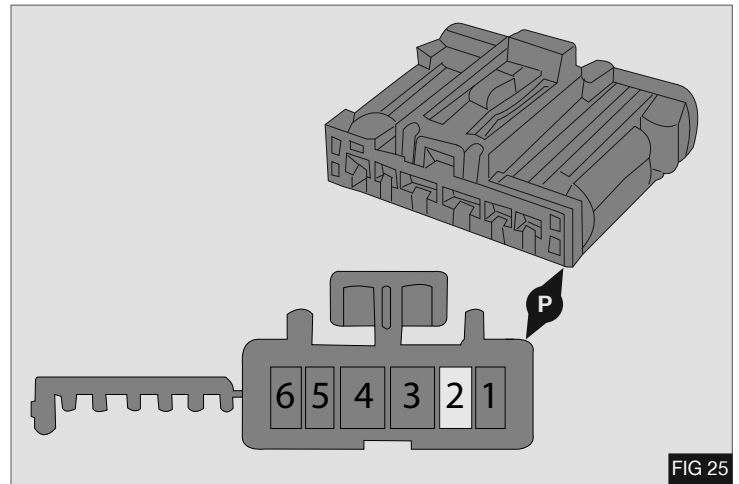

FIG 25

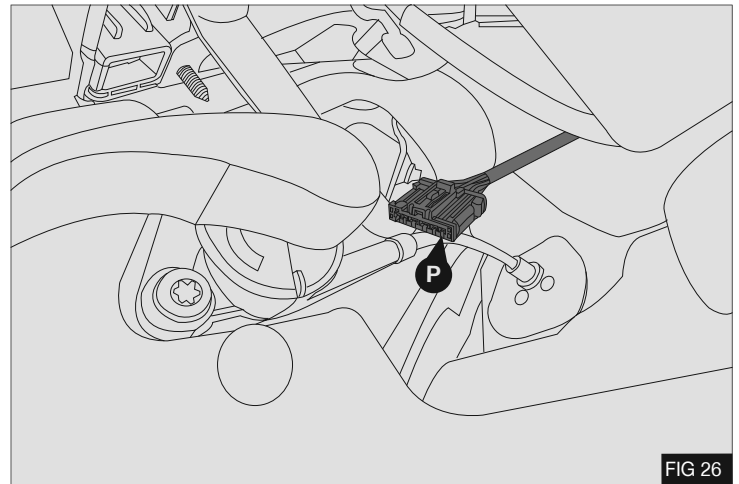

FIG 26

Ways (pins)	Connections	Allocations
1	BMT2	+12V "engine running" information (max.8A wire section 1mm <sup>2</sup> )
<b>2</b>	<b>3ADA</b>	<b>Fast idle control (500Ma max. wire section 0.35mm<sup>2</sup>)</b>
3	SBP4	+12V load shedding (max 16A wire section 1.5mm <sup>2</sup> )
4	LPH	+12V side lights (lamp) (max 16A wire section 1.5mm <sup>2</sup> )
5	H1	"Ground" information - park brake on (500Ma max. wire section 0.35mm <sup>2</sup> )
6	MAN	Ground - (section large enough to adapt to the +12V current distribution (wire section 1.5mm <sup>2</sup> ))

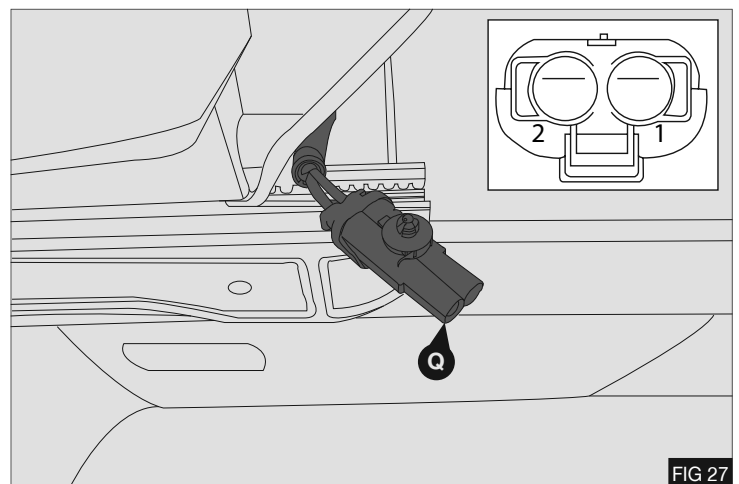
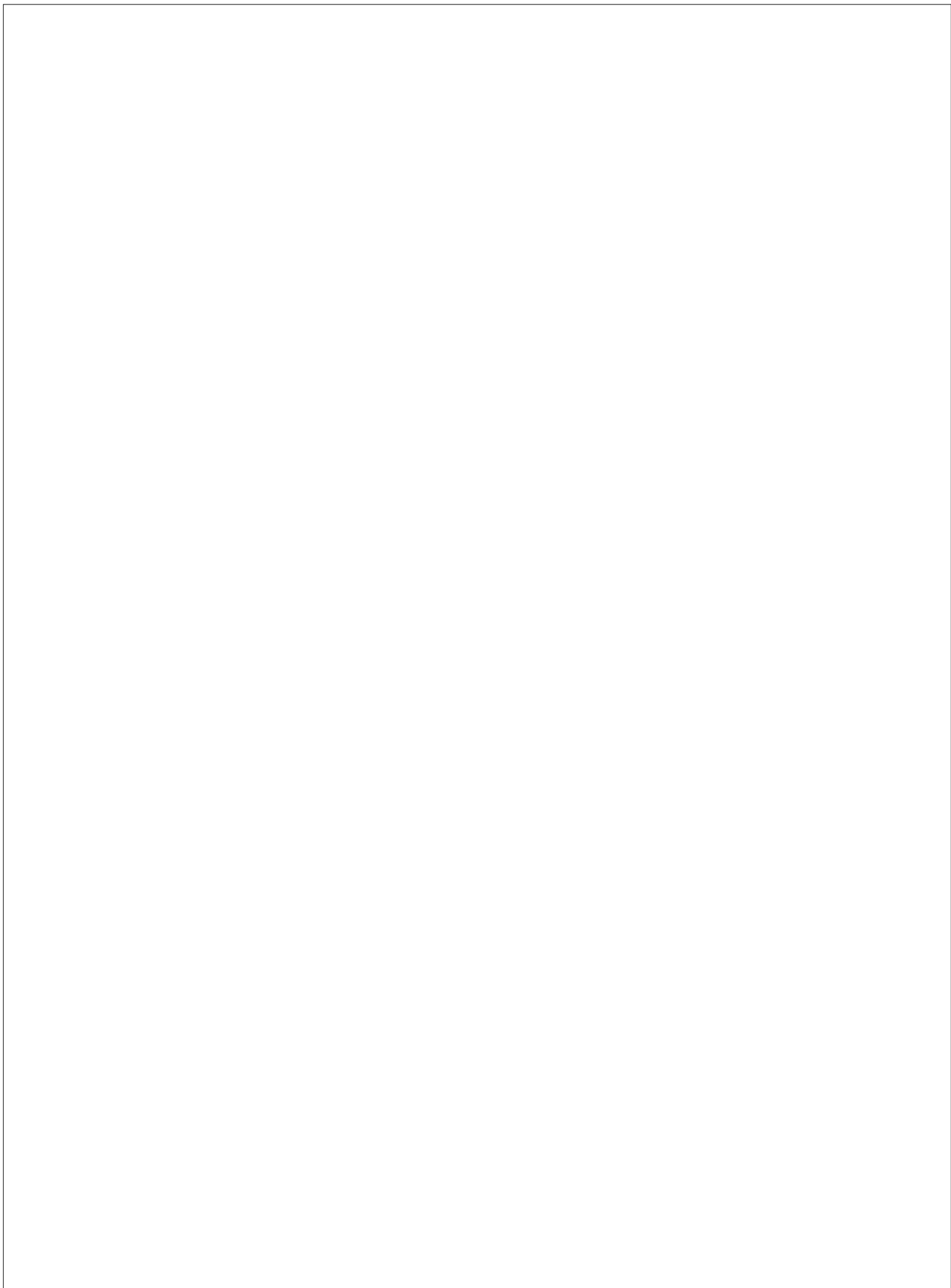

FIG 27



(EN)

Techni focuses on constant upgrading of its products. The Manufacturer reserves the right to modify the models and components described in the present publication at any time for technical or commercial reasons and without prior notice. For further information, contact Techni technical services.

(DE)

Techni ist stets bestrebt die eigenen Produkte zu verbessern. Die Herstellerfirma behält sich das Recht vor, aus technischen oder Verkaufsgründen, zu jeder Zeit und ohne vorherige Ankündigung, Abänderungen an den Modellen und den in dieser Veröffentlichung beschriebenen Einbauteile vorzunehmen. Für weitere Informationen bitten wir Sie, sich an unseren Techni Kundendienst zu wenden.

(FR)

Techni vise à une amélioration constante des ces produits. La maison se réserve le droit d'apporter, à tout moment et sans préavis, des modifications aux modèles et aux composants décrits dans cette publication pour des raisons d'ordre technique ou commerciale. Pour d'ultérieures informations s'adresser au service d'assistance Techni.

(IT)

Techni mira ad un costante miglioramento dei propri prodotti. La Casa si riserva il diritto di apportare in qualunque momento e senza preavviso modifiche ai modelli e ai componenti descritti in questa pubblicazione per ragioni di natura tecnica o commerciale. Per ulteriori informazioni rivolgersi al servizio assistenza Techni.

(ES)

Techni aspira a un constante mejoramiento de su producción. La Fábrica se reserva el derecho de aportar en cualquier momento y sin preaviso modificaciones a los modelos y los componentes descritos en esta publicación por razones técnicas o comerciales. Para ulteriores informaciones dirigirse al servicio asistencia Techni.

VENDITA E SERVIZIO  
VENTE ET SERVICE

SALES AND SERVICE  
VERKAUF UND SERVICE



Sundorne Trade Park, Henley Way,  
Shrewsbury, United Kingdom, SY1 4NS  
Telephone (+44) (0) 1743 443176  
Fax (+44) (0) 1743 443113  
Email: [sales@techni.co.uk](mailto:sales@techni.co.uk)